

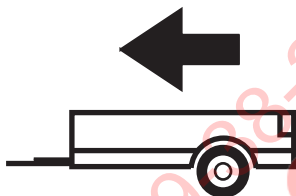

03/2010 -

AUDI A8 4D., Quattro, Long

Cat. No. A/022



2300kg



100kg

D = 12,60kN

D (kN) =



MAX kg

x

MAX kg

x 0,00981



MAX kg

+

MAX kg

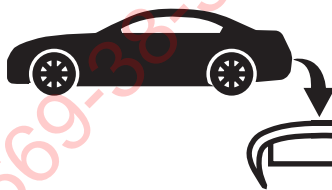

IMIOLA HAK-POL

96-111 KOWIESY, CHOJNATA 23A, POLAND

Tel. + 48 46 831 73 31, fax +48 831 74 29

e-mail: office@imiola.pl, www.imiola.pl

PRZEKRÓJ A-A

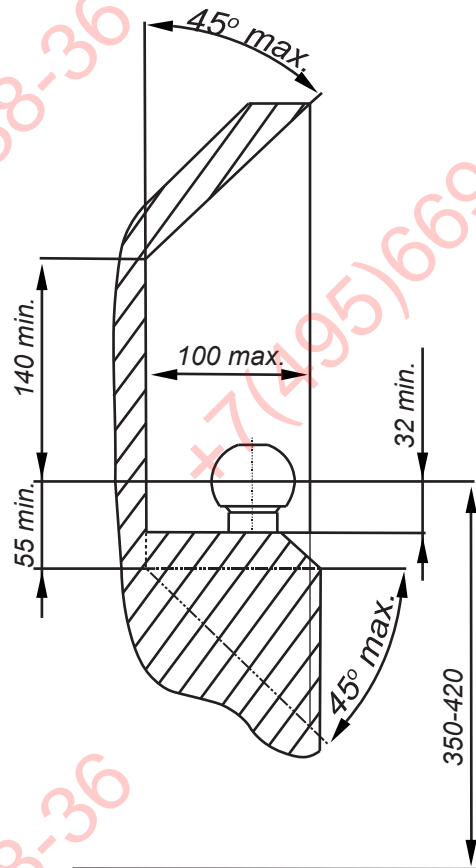
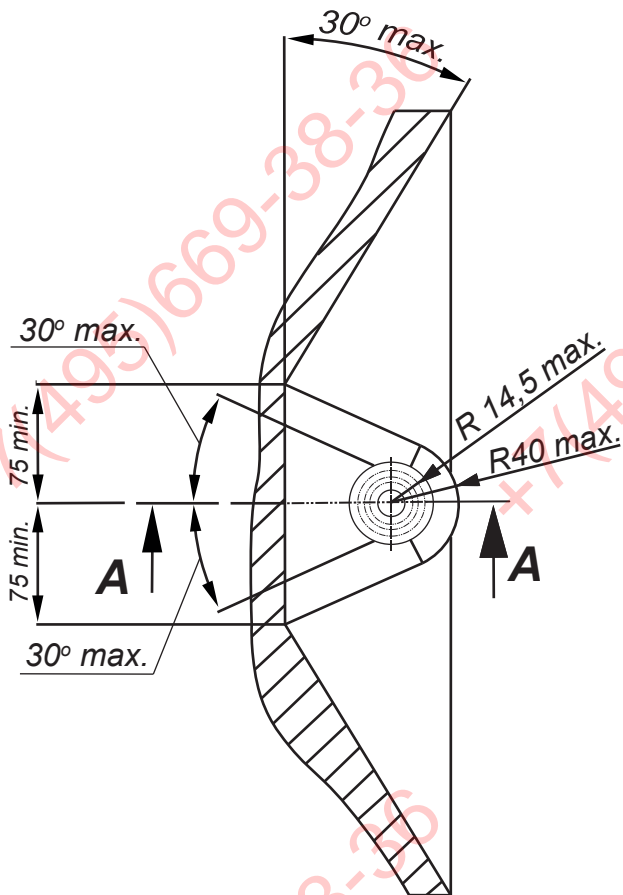

ΦАРКОП.РФ

PL Należy zagwarantować przestrzeń swobodną według załącznika VII, rysunek 25a/b Regulaminu EKG ONZ 55.01 przy dopuszczalnym ciężarze całkowitym pojazdu.

F L'espace libre doit être garanti conformément à l'annexe VII, illustration de la réglementation 55.01 CE pour un poids total en charge autorisé du véhicule.

GB The clearance specified in appendix VII, diagram 25a/b of Regulation No. 55.01 UN EU must be guaranteed at laden weight of the vehicle.

D Der Freiraum nach Anhang VII, Abbildung 25a/b der Vorschriften 55.01 EG ist zu gewährleisten bei zulässigem Gesamtgewicht des Fahrzeuges.





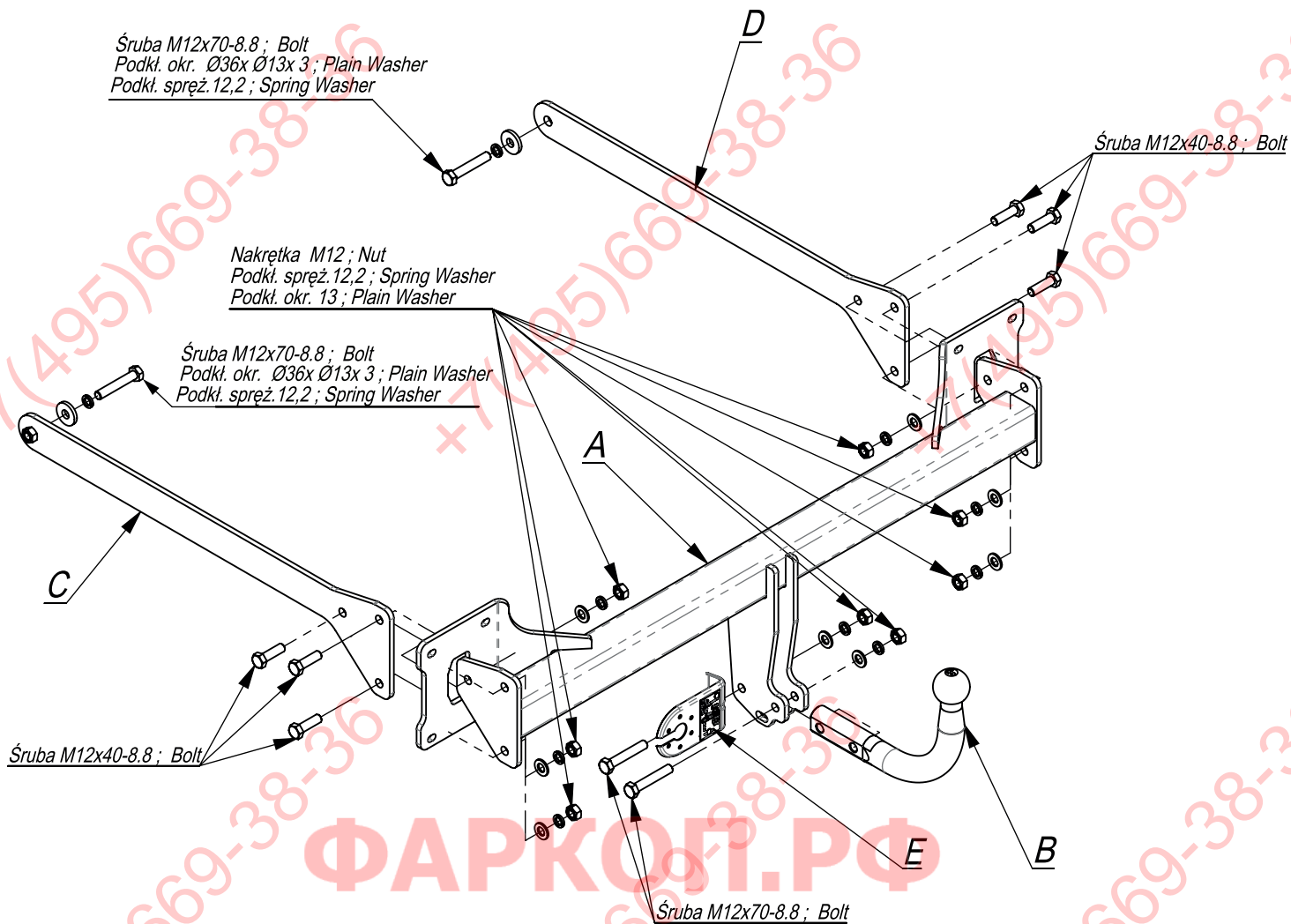



| Moment skręcający dla śrub i nakrętek (8.8) Torgue settings for nuts and bolts (8.8) | |
|---|-------|
| M8 | 25Nm |
| M10 | 55Nm |
| M12 | 85Nm |
| M14 | 135Nm |
| M16 | 195Nm |

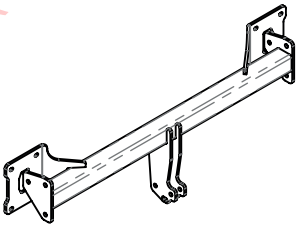
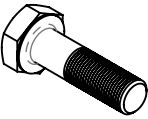
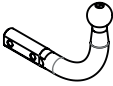



ФАРКОП.РФ

+7 (495) 669-38-36

| | | | | | |
|---|---|----|--|-----------|----|
|  | A | x1 |  | M12x70 | 4 |
| | | | | M12x40 | 6 |
|  | B | x1 |  | M12 | 8 |
|  | C | x1 |  | Ø36xØ13x3 | 2 |
|  | D | x1 |  | 13 | 8 |
|  | E | x1 |  | 12,2 | 10 |

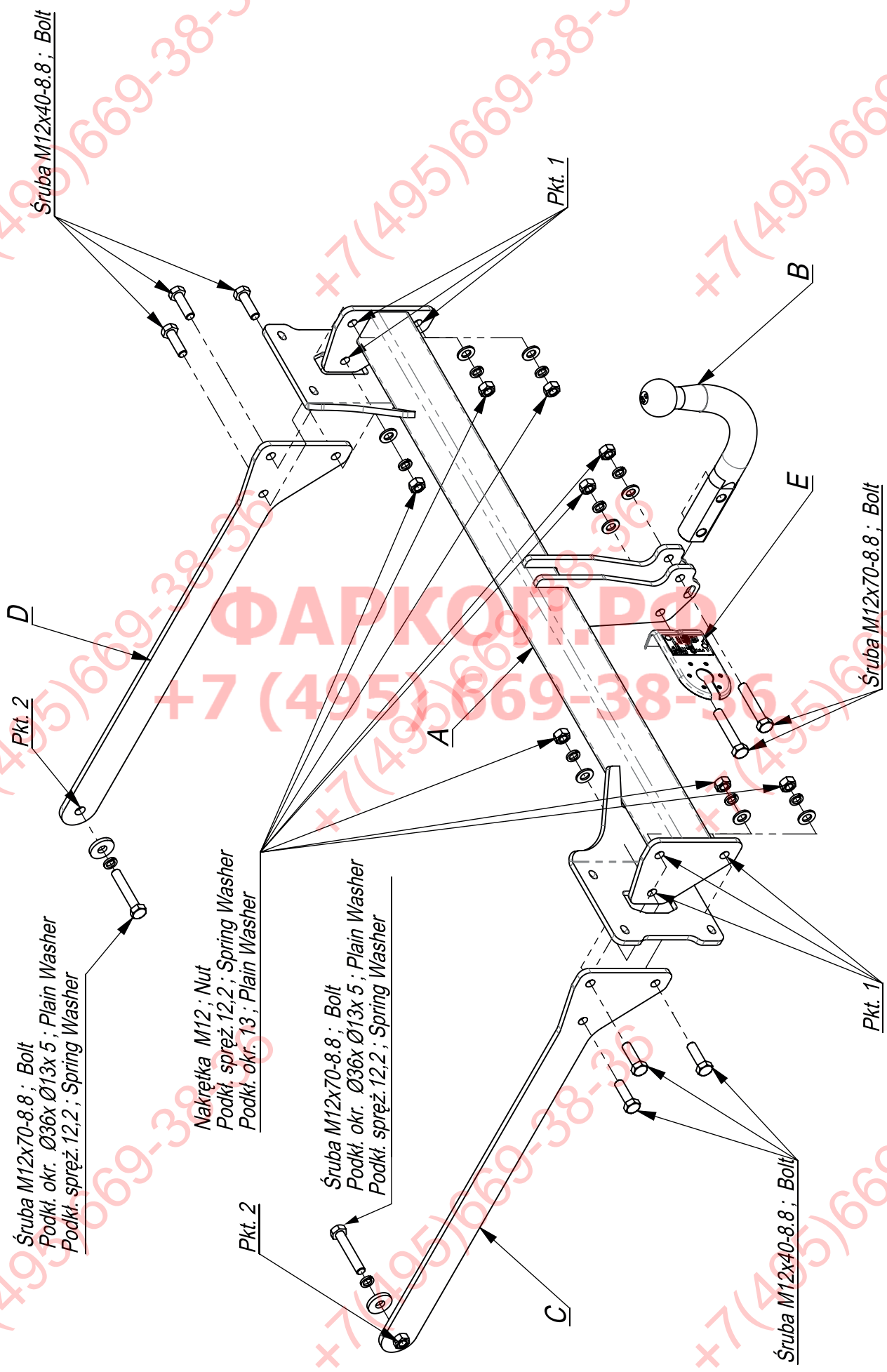

+7(495)669-38-36

ΦΑΡΚΟΤΡΟ

+7(495)669-38-36

+7(495)669-38-36

+7(495)669-38-36

+7(495)669-38-36

+7(495)669-38-36

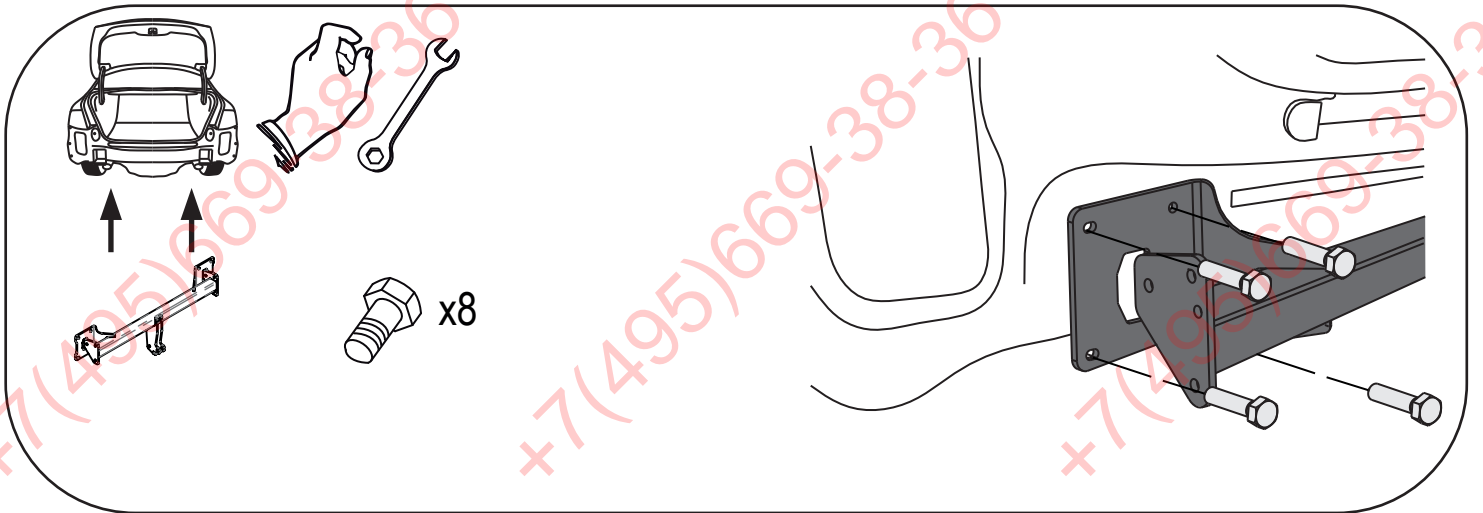
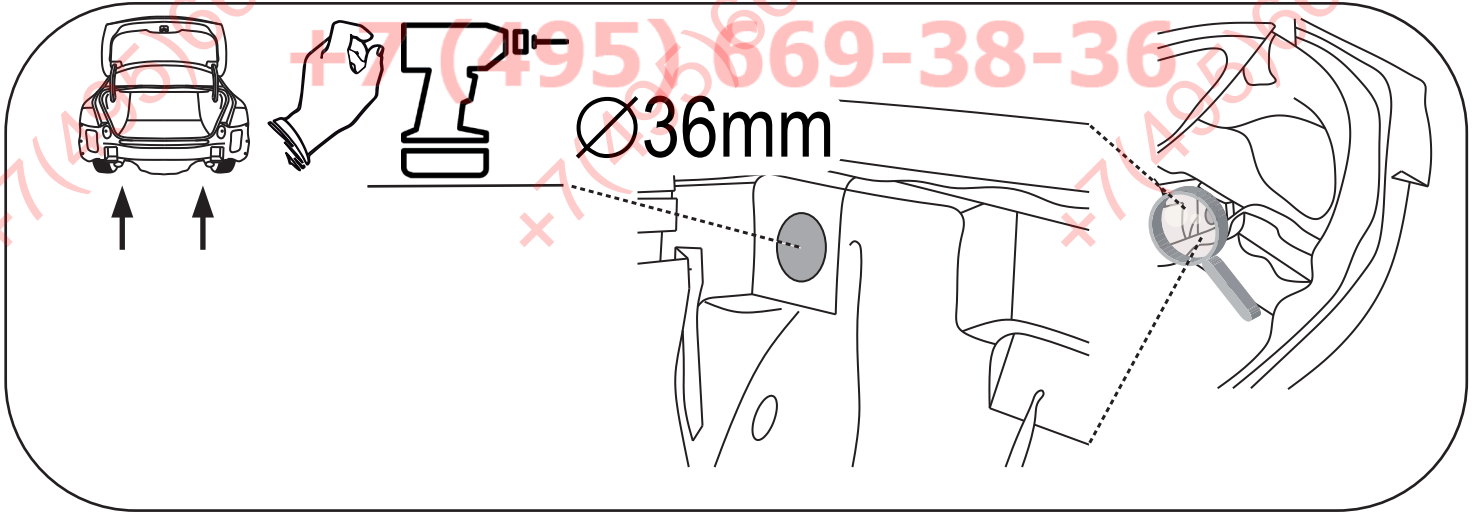
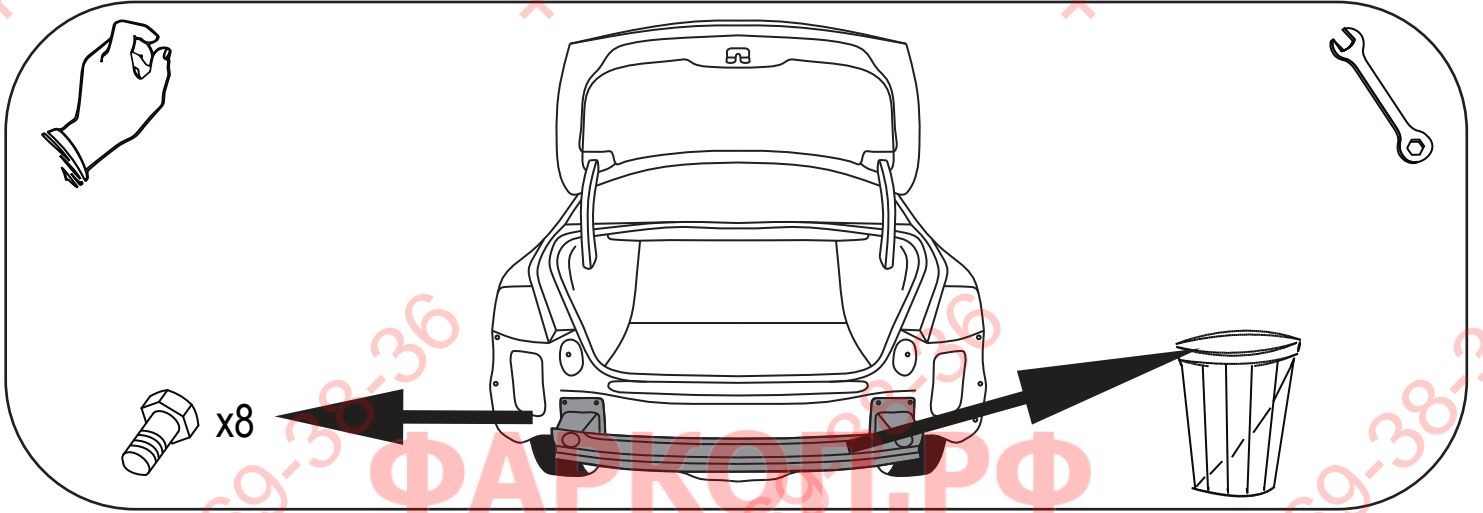
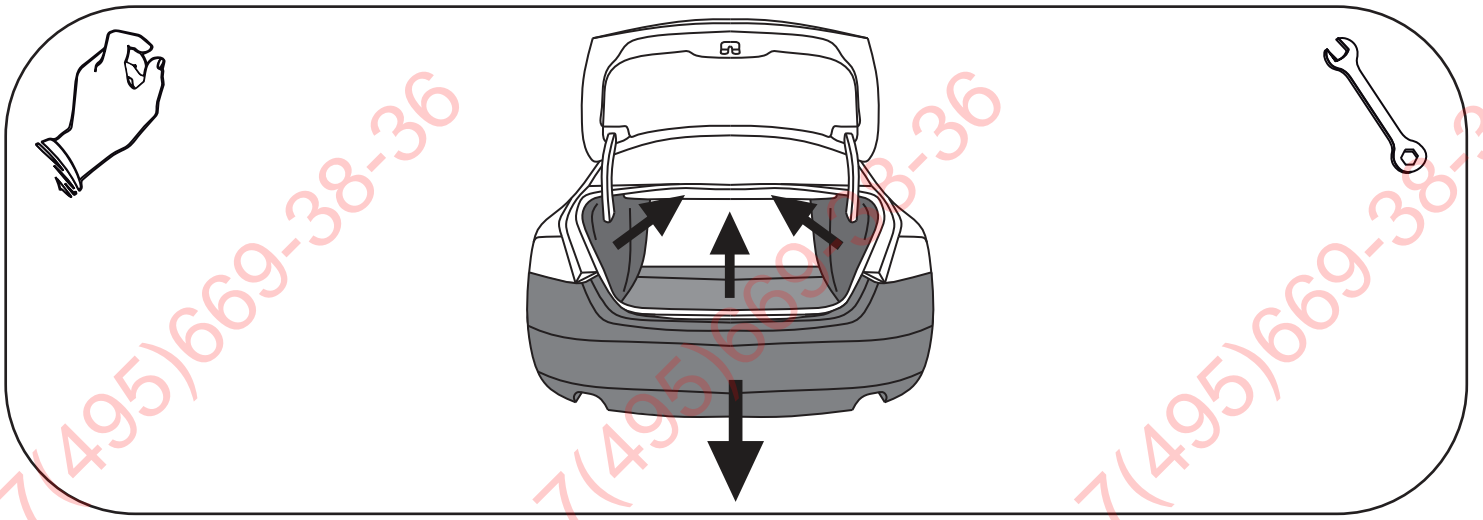

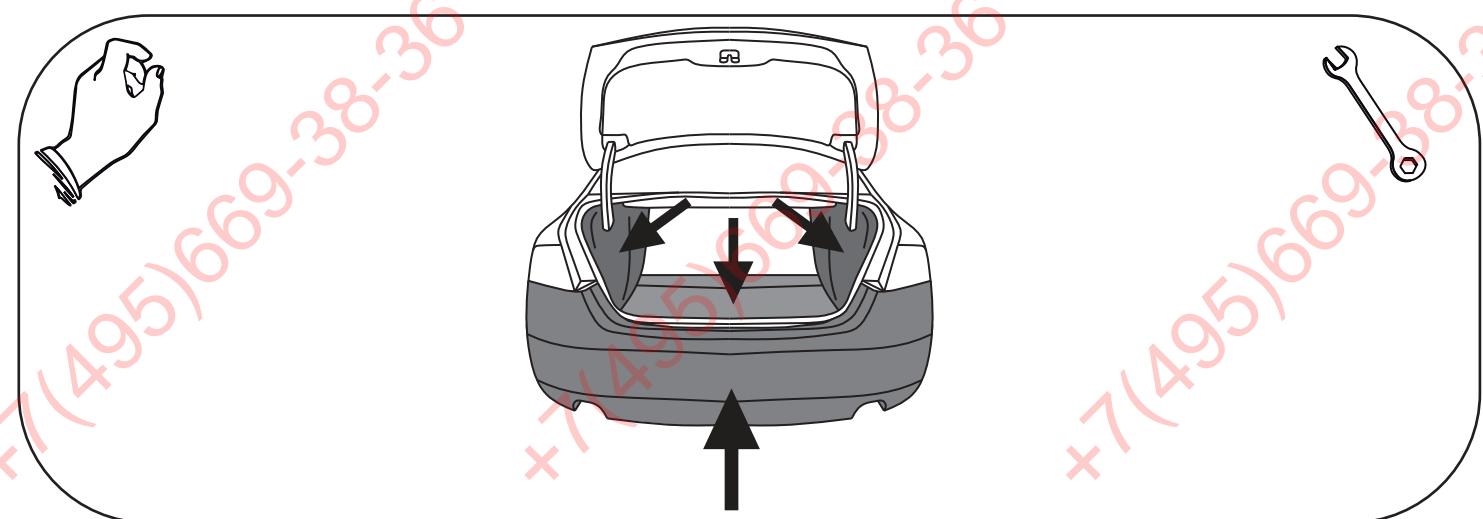
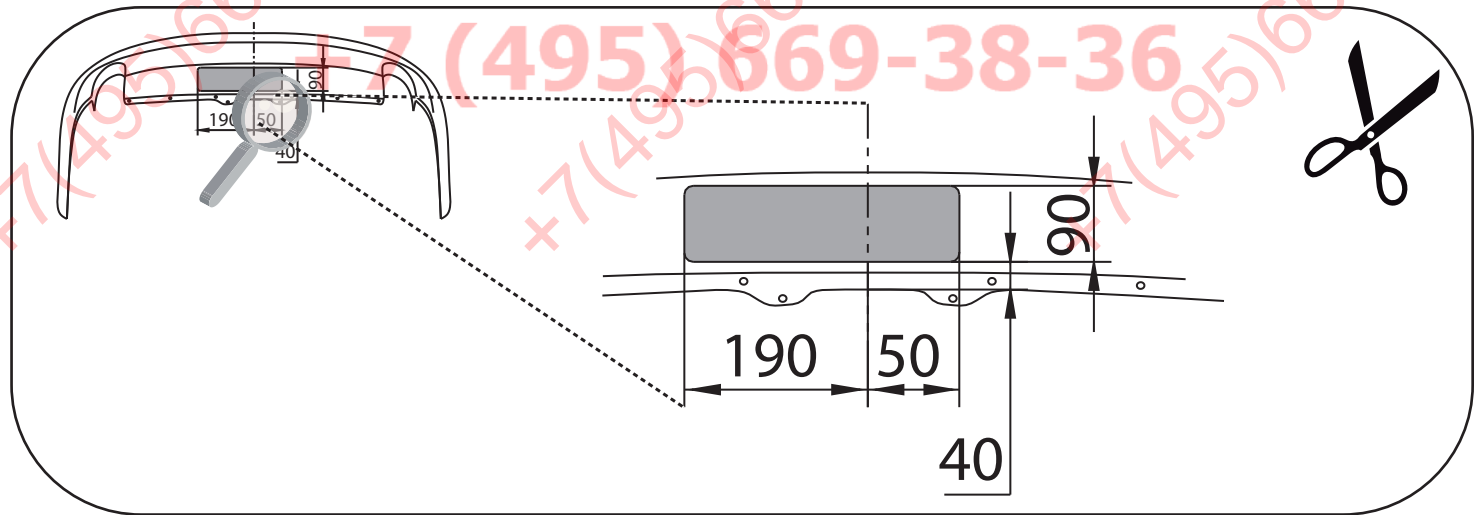
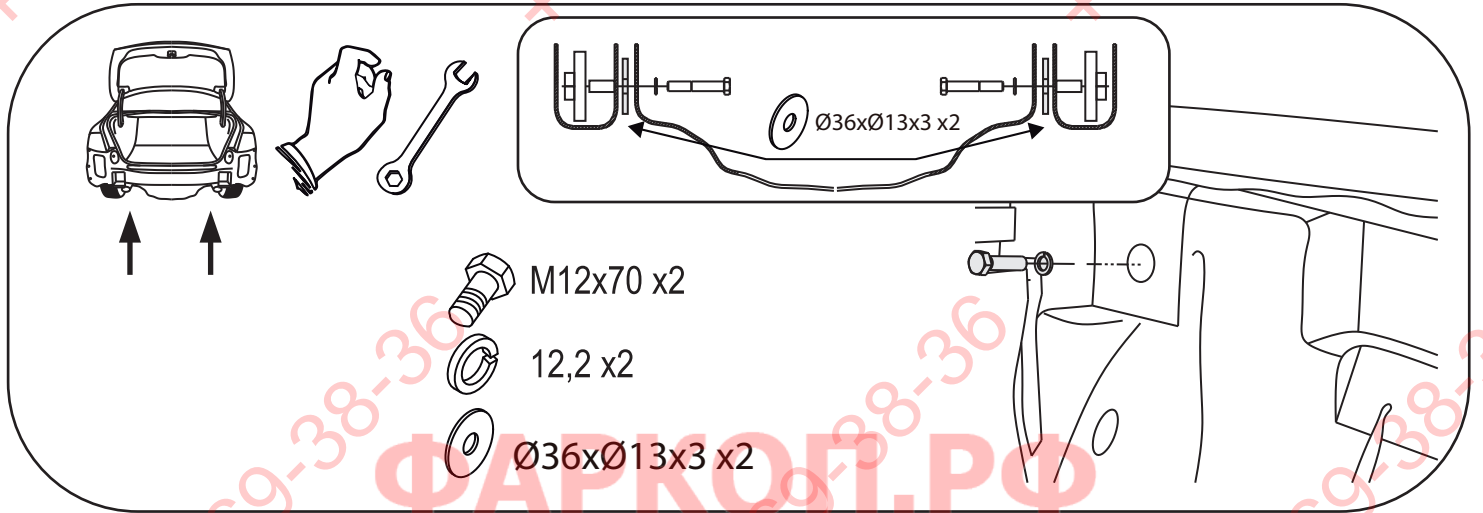
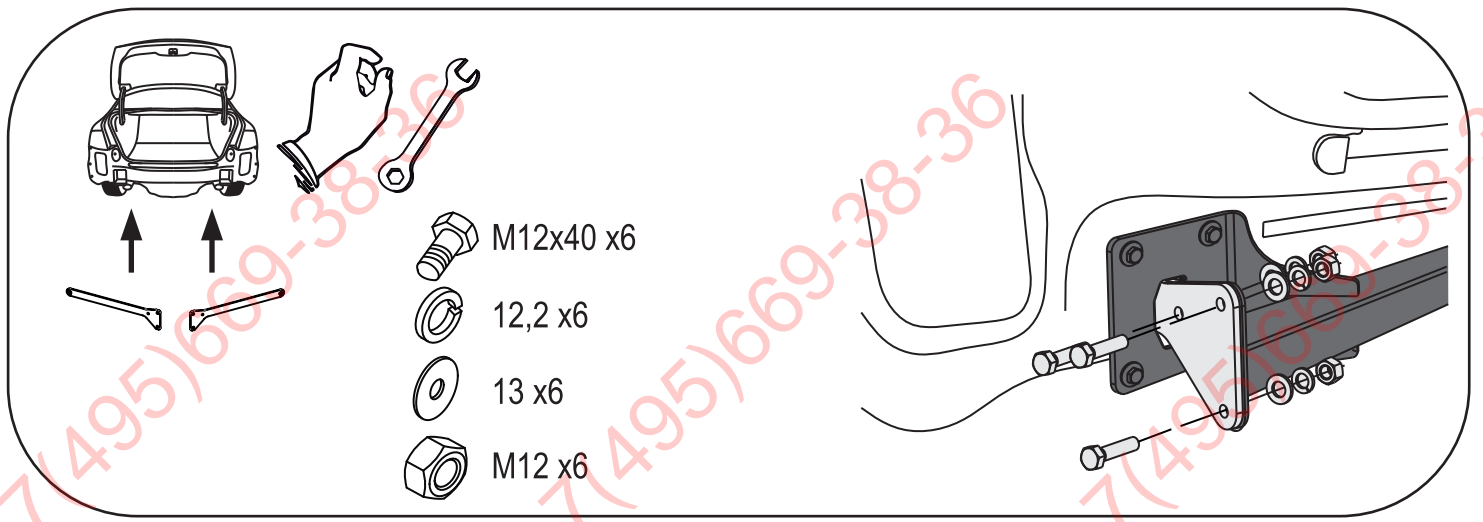

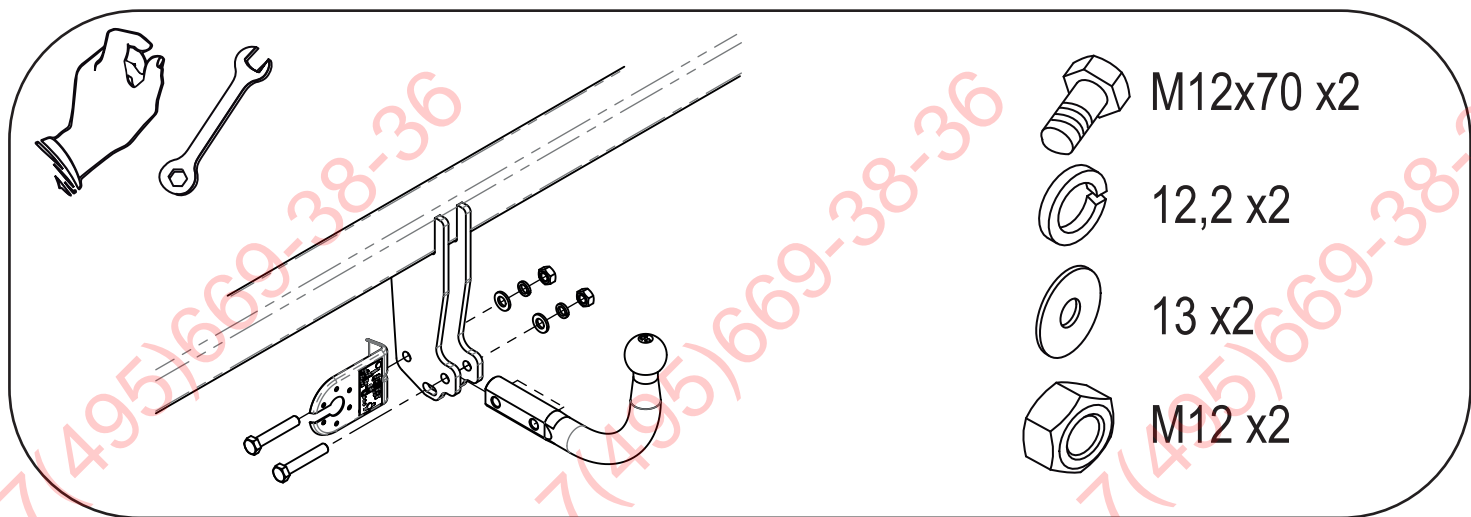

ФАРКОГ.РФ

+7 (495) 669-38-36